

GATE VALVE

# Gate Valve

REF **EFC-52** ISSUED **05 Jun 2026**

## SPECIFICATIONS

Size	<b>DN40–DN1000</b>
Pressure	<b>PN10–PN40</b>
End connection	<b>flanged (DIN EN 1092-2/B)</b>
Face-to-face	<b>EN 558 Serie 15, DIN3202 F5</b>
Temperature	<b>-20°C to 120°C</b>

## ACTUATION

- handwheel — GG 20 cast iron handwheel

## STANDARDS

Design	<b>EN 1171, DIN 3352</b>
Test	<b>EN 12266</b>

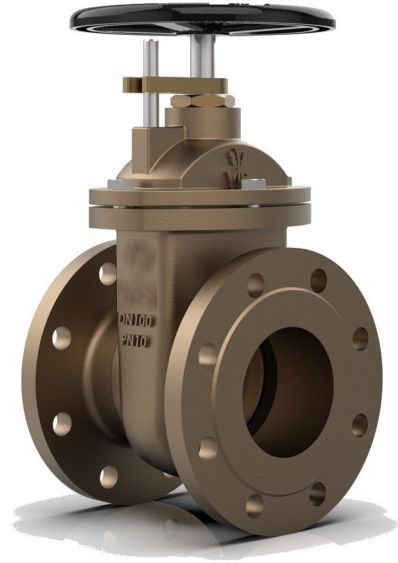

**MATERIALS**

body	cast iron, ductile iron, cast steel, bronze, stainless steel	seat	brass, bronze, stainless steel
wedge	cast iron, ductile iron, cast steel, bronze, stainless steel	stem	stainless steel, brass, copper alloy, bronze
gasket	elastomer, fibre, graphite	bonnet	cast iron, ductile iron, cast steel, bronze, stainless steel
o ring	elastomer	packing	graphite
handwheel	cast iron		

**PRESSURE-TEMPERATURE RATING**

CLASS	TEMPERATURE	MAX PRESSURE
PN16 (Cast Iron GG25, DN40-DN600)	20°C	16 bar
PN10 (Cast Iron GG25, DN700-DN1000)	20°C	10 bar
PN25 (Ductile Iron GGG40, DN40-DN600)	20°C	25 bar
PN16 (Ductile Iron GGG40, DN700-DN1000)	20°C	16 bar

GATE VALVE

# Gate Valve

SECTION Technical drawing REF EFC-52

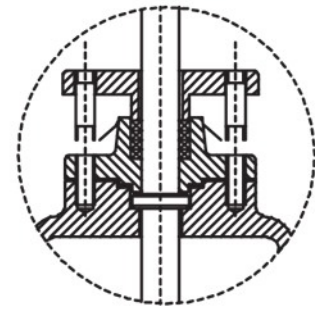
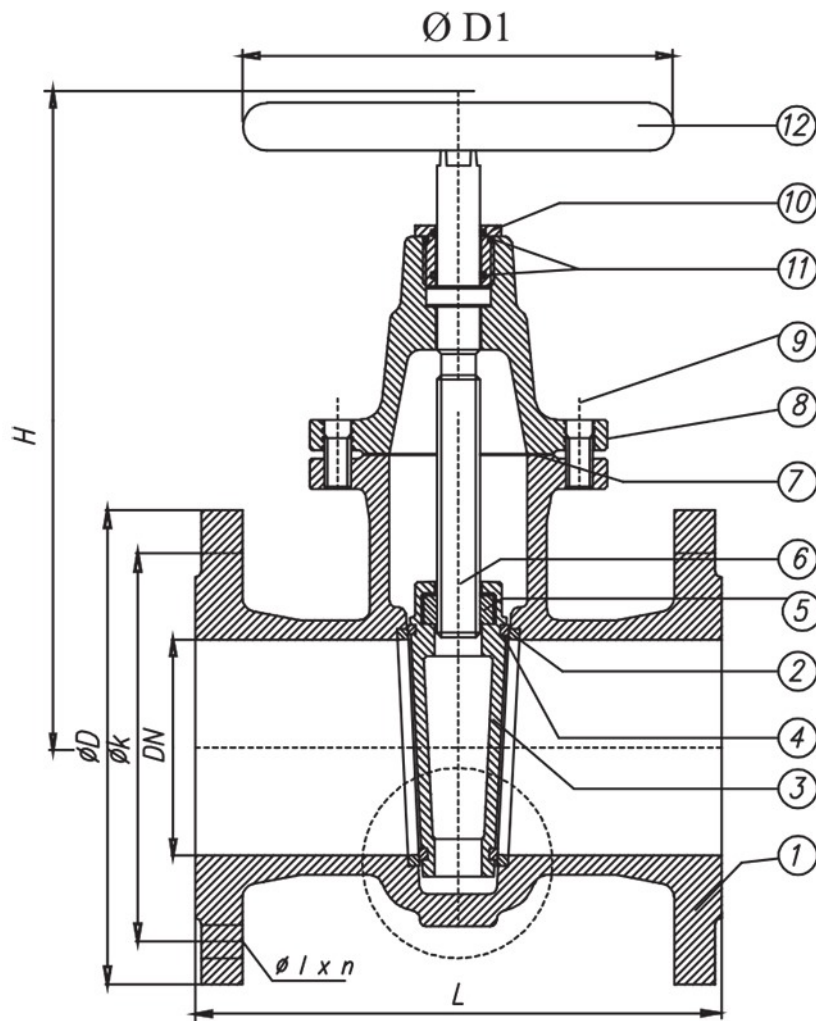

**Packing Detail**  
Salmastra Detayı

GATE VALVE

# Gate Valve

SECTION Dimensions per size REF EFC-52

SIZE	L	H	WEIGHT
DN40	240	215	13 kg
DN50	250	220	15 kg
DN65	270	265	22 kg
DN80	280	300	27 kg
DN100	300	320	36 kg
DN125	325	370	47 kg
DN150	350	415	59 kg
DN200	400	590	141 kg
DN250	450	675	195 kg
DN300	500	750	285 kg
DN350	550	870	371 kg
DN400	600	950	460 kg
DN500	700	1200	751 kg
DN600	800	1330	1143 kg

## Gate Valve

Dimensions per size (continued) · EFC-52

SIZE	L	H	WEIGHT
<b>DN700</b>	900	1530	1330 kg
<b>DN800</b>	1000	1690	2300 kg
<b>DN900</b>	1100	1925	3400 kg
<b>DN1000</b>	1200	2160	4300 kg

*All dimensions in millimetres unless stated otherwise. Values are nominal; tolerances confirmed at quote.*