

JIS VALVE

JIS 5K Angle Globe Valve

REF **EFC-134** ISSUED 05 Jun 2026

SPECIFICATIONS

Size	DN15–DN65
Pressure	5K
End connection	flanged (JIS B2240)
Temperature	-999°C to 205°C
Media	air, gas, oil, pulsation water, steam, water

ACTUATION

- manual handwheel — GG 25 handwheel

STANDARDS

Design	JIS F7302, JIS F7352
Test	JIS F7400

APPLICATIONS

- air
- gas
- oil
- pulsation water
- steam
- water



MATERIALS

body	bronze	bonnet	bronze
disc	brass, bronze	stem	brass
handwheel	grey cast iron	packing	graphite
gasket	non-asbestos		

FEATURES

- Available in STOP (JIS F7302) and Screw Down Non Return SDNR (JIS F7352) configurations
- Angle pattern body design
- Flanged ends to JIS B2240-5K
- Graphite packing
- Non-asbestos gasket

JIS VALVE

JIS 5K Angle Globe Valve

SECTION Technical drawing REF EFC-134

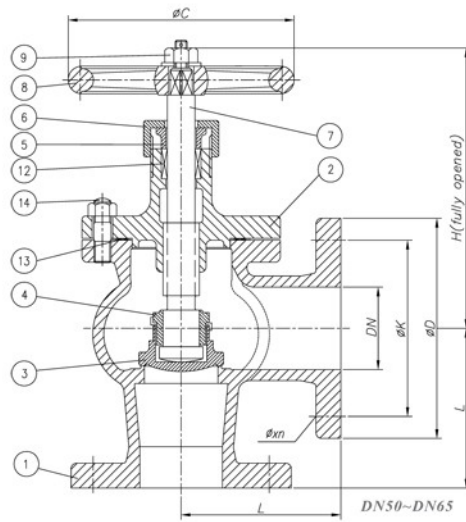
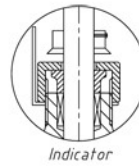
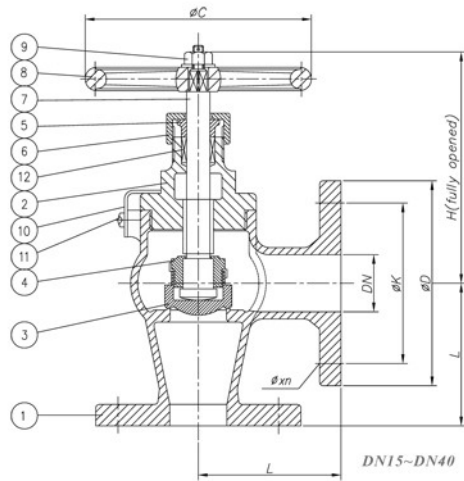

JIS VALVE

JIS 5K Angle Globe Valve

SECTION Dimensions per size REF EFC-134

SIZE	L	H	C	D	K	ØXN	WEIGHT
DN15	55	120	80	80	60	Ø12x4	1.98 kg
DN20	60	130	100	85	65	Ø12x4	2.73 kg
DN25	65	145	125	95	75	Ø12x4	3.44 kg
DN32	80	150	125	115	90	Ø15x4	4.77 kg
DN40	85	165	140	120	95	Ø15x4	5.99 kg
DN50	100	200	140	130	105	Ø15x4	10.1 kg
DN65	115	220	160	155	130	Ø15x4	15.6 kg

All dimensions in millimetres unless stated otherwise. Values are nominal; tolerances confirmed at quote.